

End Pipe Wrenches

Capacity: 3/4" through 5"

NOTE: Order parts by Catalog Number only.
DO NOT order by Reference Number.

Aluminum Wrenches

Model Pipe Capacity		E-910 1 1/2"	E-914 2"	E-918 2 1/2"	E-924 3"
Ref. No.	Description	Catalog No.	Catalog No.	Catalog No.	Catalog No.
1	Handle Assembly	93907	93912	93917	93922
2	Nut	31615	31665	31685	31710
3	Pin	95402	95407	31690	31690
4	Heel Jaw Assembly	31610	31635	31675	31700
5	Spring Assembly	31620	31660	31680	31705
6	Hook Jaw	31605	31655	31670	31695

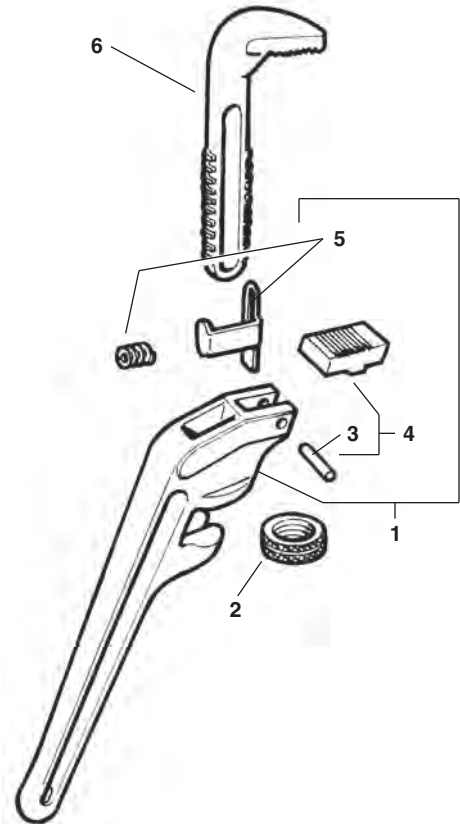

Steel Wrenches

Model Pipe Capacity		E-6 3/4"	E-8 1"	E-10 1 1/2"	E-12 2"	E-14 2"	E-18 2 1/2"	E-24 3"	E-36 5"
Ref. No.	Description	Catalog No.	Catalog No.	Catalog No.	Catalog No.	Catalog No.	Catalog No.	Catalog No.	Catalog No.
1	Handle Assembly	31470	31475	31480	31485	31490	31495	31500	31505
2	Nut	31570	31595	31615	31645	31665	31685	31710	31735
3	Pin	31575	31600	31625	31650	31650	31690	31715	31740
4	Heel Jaw Assembly	31560	31585	31610	31635	31635	31675	31700	31725
5	Spring Assembly	31565	31590	31620	31640	31660	31680	31705	31730
6	Hook Jaw	31555	31580	31605	31630	31655	31670	31695	31720

Offset Wrenches

		14 1/8"-2"	18 1/4"-2 1/2"	24 1/4"-3"
Ref. No.	Description	Catalog No.	Catalog No.	Catalog No.
1	Hook Jaw	32490	32505	32520
2	Heel Jaw Assembly	31635	31675	31700
3	Pin	31650	31690	31715
4	H.D. Handle Assembly	92080	92085	92090
5	Alum. Handle Assembly	32480	32495	32510
6	Spring	32485	32500	32515
6	Nut	31665	31685	31710

